



THE MOST
COMPACT
AND RELIABLE
SOLUTION
FOR SOLAR
PUMPING
APPLICATIONS



SOLAR PUMPTEC
SOLAR PUMPING SPECIALISTS

NASTEC®
> we move it faster >

NERA solar pumps have been developed to meet the needs of low-power and low-cost pumping systems without sacrificing quality, reliability and performance.

For this reason, unique technical features are integrated in NERA.

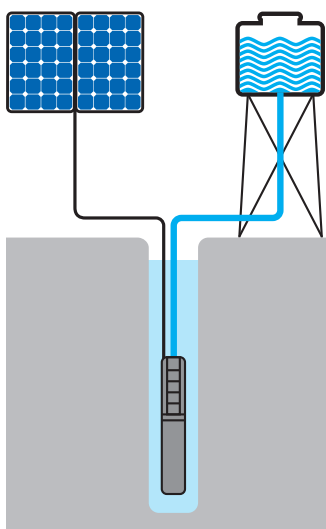

CENTRIFUGAL PUMP

- Impellers and diffusers in AISI 304 stainless steel
- Built-in no return valve

ENCAPSULATED ELECTRONICS

- High-efficiency encapsulated inverter
- MPPT for maximum flow in all weather conditions
- Overload, overheating and dry-run protected
- Removable power cable
- Water level sensor





HELICAL ROTOR PUMP

- Highest hydraulic efficiency
- Hard chromed rotor
- High quality EPDM stator

SUMMAG Solar ER MOTOR

- High efficiency permanent magnet motor
- NEMA standard 4" fitting
- Resined and encapsulated stator made of AISI 304 stainless steel
- Water-cooled rotor
- Kingsbury thrust bearing

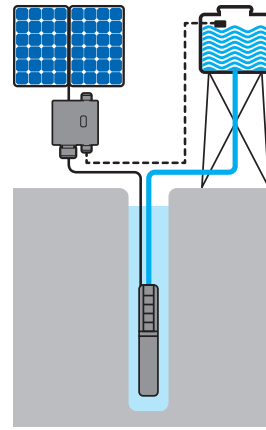

To connect NERA to the solar system, the STOP MODULE device is available as an accessory. It is equipped with:

- MC4 connectors for fast and easy panels connection
- Button for pump start and stop
- Connection for float or pressure switch
- Surge protection



MPPT: ALWAYS THE MAXIMUM POWER AVAILABLE

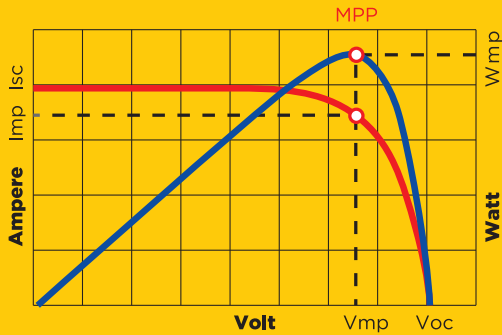

Based on the varying conditions of solar irradiation and temperature, MPPT (Maximum Power Point Tracking) maximises the electrical power drawn from the panels and therefore the amount of water pumped. The greater the solar irradiation the faster the pump's rotation speed, and consequently water flow increases.

When solar irradiation decreases (due to clouds or the different times of day), the pump reduces frequency and therefore the flow, but it continues to provide water until the irradiation falls below a minimum level necessary to ensure operation.

PUMP SELECTION

For the correct selection of NERA pump to be used in a photovoltaic system, it is necessary to know:

- desired daily water flow
- total head
- installation location

Based on the location it is possible to calculate average daily radiation [kWh/m²/day]. Average daily radiation can then be considered as the number of hours the pump works with 1 kW/m², standard for defining solar panel performance. Dividing the required water quantity by the hours, nominal flow is calculated and, in addition to the required head, the right pump can be selected.

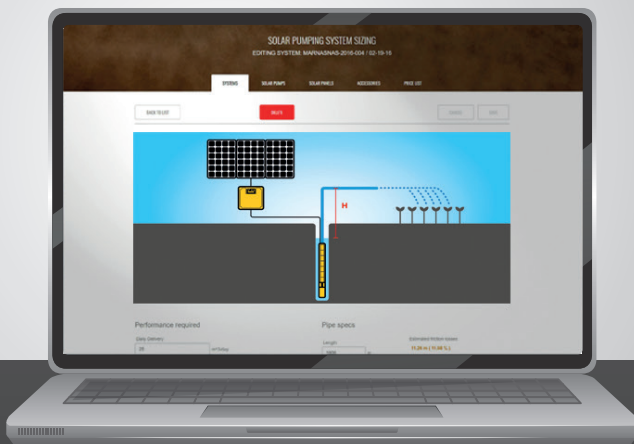
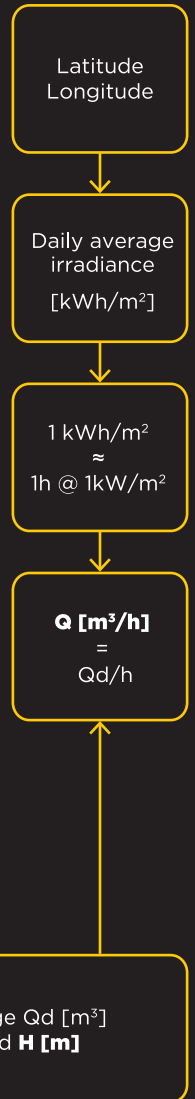

For a full sizing of your solar pumping system, it is recommended using Nastec Solar Calculator (NSC) at:

solar.nastec.eu



NERA 01/02H

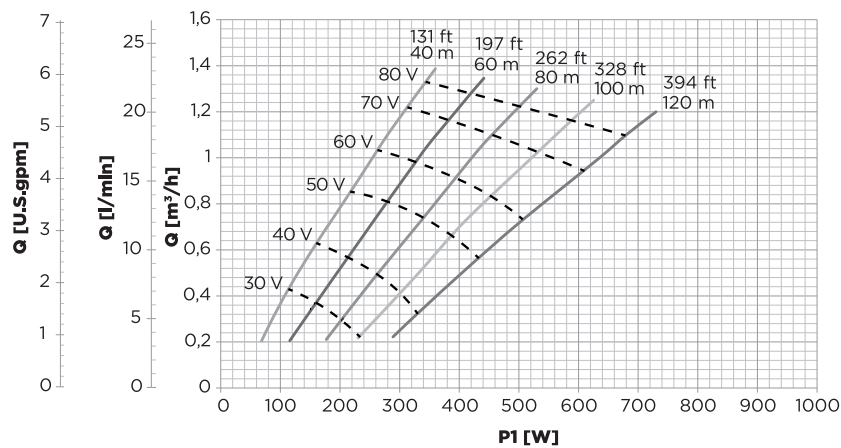

NERA 02/01H

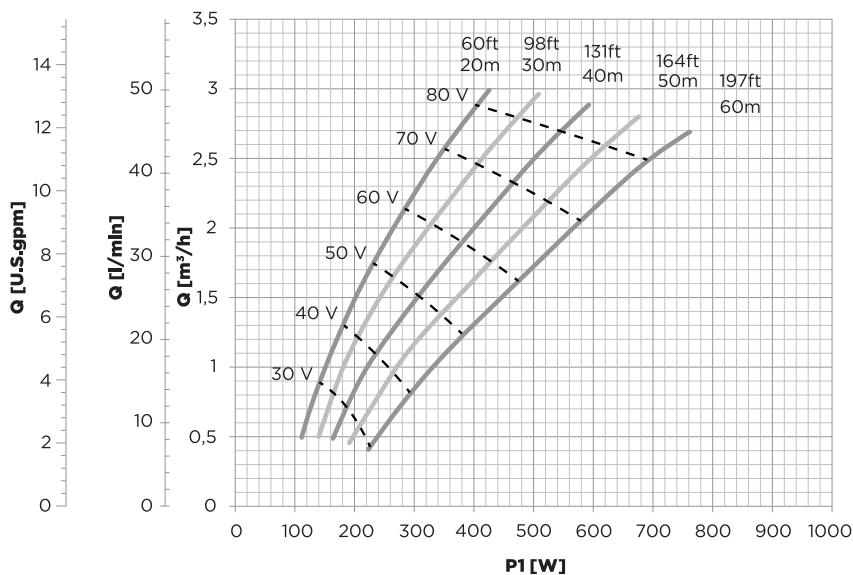

NERA 06/04

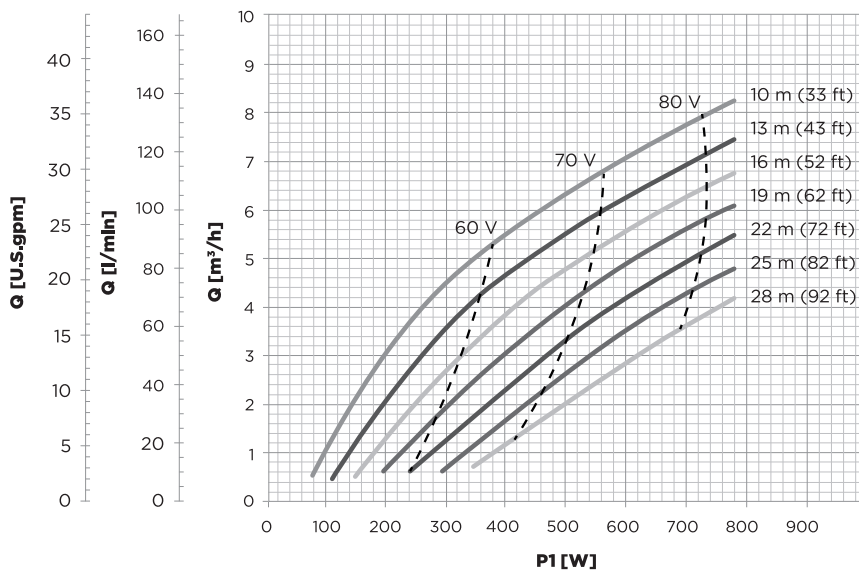

Model	Voltage	Max current	Max power	Length	Discharge	Pump weight	Max diameter*	Packing dimensions	Total weight
NERA	VDC	A	P1 [W]	mm		kg	mm	cm	kg
01/02H	26 - 190	10	800	940	1 1/4 "	12,8	93*	120x16x21	13,4
02/01H	26 - 190	10	800	880	1 1/4 "	11,9	93*	120x16x21	12,3
06/04	26 - 190	10	800	531	1 1/2 "	10,9	98*	58x11x13	11,3

* Max external diameter including cable and cable cover

MATERIALS

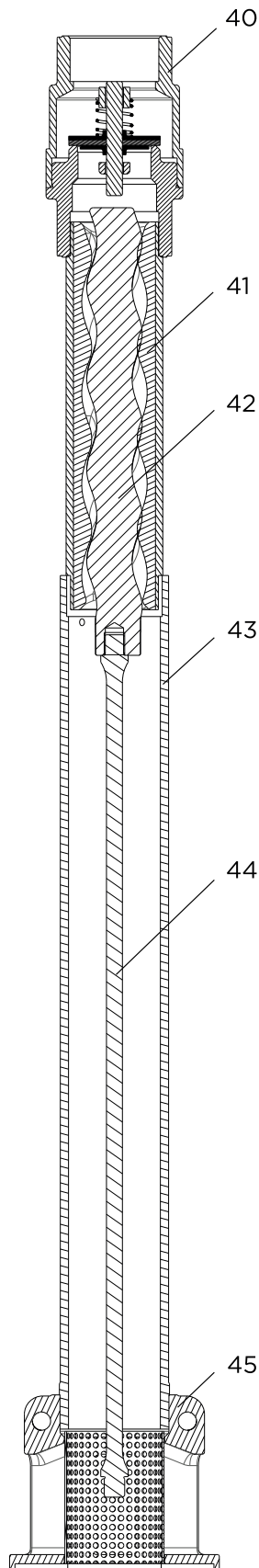
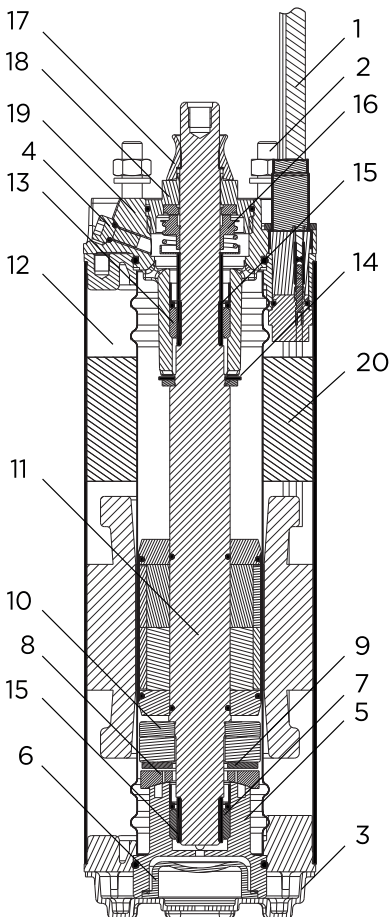
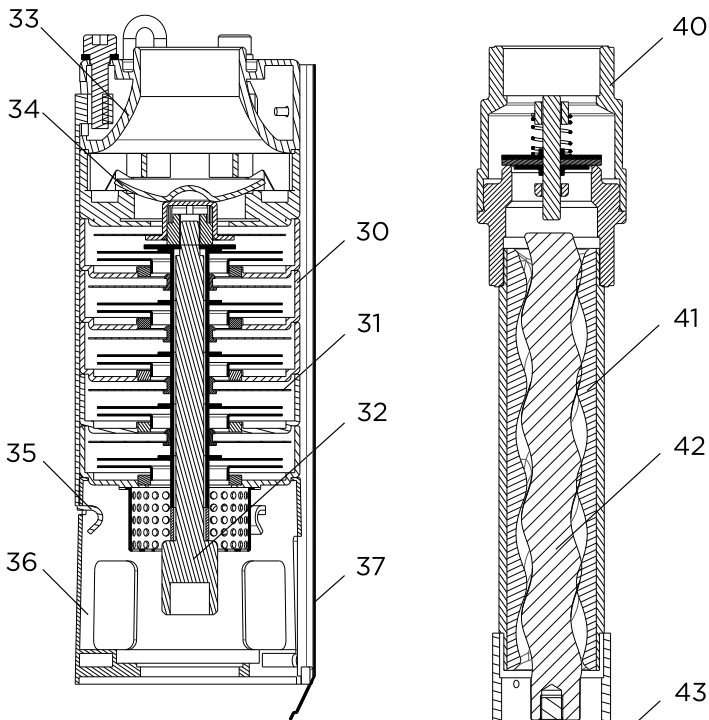

Ref	Description	Material
MOTOR		
1	Power supply cable with removable connector for drinking water applications	2m flat cable ACS-WRAS-KTM approved
2	M8 stud	AISI 304
3	Supporto inferiore	AISI 304
4	Vite per riempimento	AISI 304
5	Lower thrust bearing	AISI 304
6	Rubber diaphragm	EPDM
7	Lower bush	SiC
8	Tilting disc	AISI 304
9	Pads	AISI420j
10	Carbon disc	CTI25
11	Shaft with rotor	AISI 431
12	Canned type stator	AISI 304
13	Upper bush	SiC
14	Upper thrust bearing	Teflon
15	Ceramized sleeve	AISI 304 + Ceramic
16	Mechanical seal	SiC
17	Rotating sandguard	NBR
18	Mechanical seal support	AISI 304
19	Pump bracket	AISI 304
20	E-Ring: Encapsulated inverter module for SUMMAG Solar ER motor	
CENTRIFUGAL PUMP		
30	Diffusers	AISI 304
31	Impellers	AISI 304
32	Pump shaft	AISI 304
33	Discharge	AISI 304
34	No-return valve	AISI 304
35	Straps	AISI 304
36	Pump bracket	AISI 304
HELICOIDAL ROTOR PUMP		
40	No-return valve	AISI 304
41	Helicoidal stator	EPDM + AISI 304
42	Helicoidal rotor	Chromated AISI 304
43	Supporting pipe	AISI 304
44	Flexible shaft	AISI 316
45	Pump bracket	AISI 304

GENERAL SPECIFICATIONS

EMC compliance	EN61800-3 C2
Insulation class of windings	Class F
Max. temperature of the pumped liquid	35 °C (92 °F)
Min liquid cooling speed	0.2 m/s (0,66 ft/s)
Characteristics of the pumped liquid	clean, chemically not aggressive, not explosive, without solid and fibre content, with max 50 g/m ³ sand content
Recommended pH	6,5 - 8,5
Maximum chlorine level	700 ppm (10 °C); 300 ppm (20 °C); 200 ppm (30 °C)
Protection degree	IP68
Maximum immersion depth	150 m (492 ft)
Motor filling liquid	70% water + 30% glycol
Materials	Motor and pump in AISI 304 stainless steel
Cable	Flat cable, 2 m in length, compliant with ACS - WRAS - KTM standards
Certifications	CE

NERA pump can be installed both vertically and horizontally, as long as the outlet is never lower than the horizontal axis.

To ensure proper cooling if NERA is not installed in a 4" well, it is necessary to use a cooling sleeve.

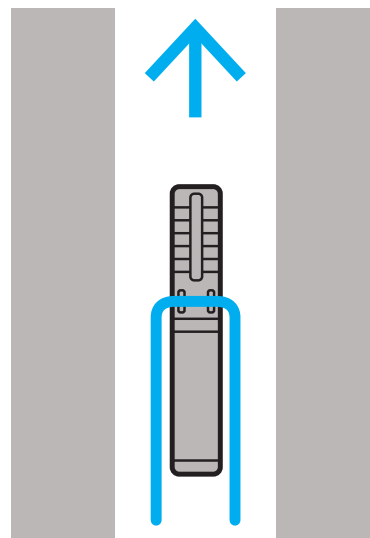
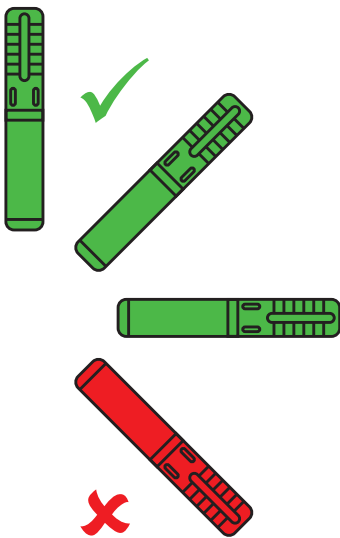

nastec.eu



We were born in 2007 with over 30 years of previous experience in water pumps.

We develop products dedicated to specific applications. We don't claim to do everything, but we strive to do the best at what we do.

We pay attention to details.

We love manufacturing and encourage every form of repair. That's why we offer spare parts.

We update our products while maintaining compatibility with the past.

We support our customers always and by every possible means.

We are global in sales but local in assistance.

Our mission? To make pumping systems intelligent, efficient, and connected.

Nastec srl

Via della Tecnica 8
36048 Barbarano Mossano
Vicenza - Italy

tel +39 0444 886289
fax +39 0444 776099
info@nastec.eu



Solar Pumptec

51 Theen Avenue
Willaston, SA 5118

(08) 8522 2762
www.solarpumptec.com.au



GFR000830_rev10 01.2024 Nastec reserves the right to modify the technical features contained in this document without notice.

